



INJECTION INTELLIGENCE



Headquarters Austria



EXPERTS SINCE 1970.
Best practice for the future.

For over 50 years, MAPLAN has been a leading manufacturer of elastomer injection moulding machines and an expert in 360-degree system solutions for semi- and fully-automated production of rubber and silicone products.

MAPLAN represents expertise and reliability since 1970. With state-of-the-art industrial technology, we continuously drive product development and optimize our production. This ensures our technological leadership for the future.

Advancement through
innovation & sustainability

Our customers benefit from MAPLAN's technological edge and our personalized consultation. MAPLAN develops and manufactures technology for the production of elastomer moulded parts—ranging from simple rubber moulded articles to precision parts with high-quality requirements. We build high-end systems for companies operating in a challenging and constantly evolving environment. Together with our customers and partners, we develop customized product solutions, creating a decisive competitive advantage for our customers to succeed in a future-oriented market.

Success with **innovative** production

At MAPLAN, we understand that time is money. Innovation in injection moulding technology means utilizing all available opportunities to optimize production processes. We apply the latest technological advancements not only in our own manufacturing but also in enhancing the production workflows of our customers. This commitment ensures that our clients benefit from the most efficient and cutting-edge solutions in the industry.

Focusing on what is important

This is just one of the reasons for introducing the innovative Lean Line Production at the MAPLAN Headquarters. Behind Lean Production always lies an increase in efficiency and the reduction of waste - internally, from suppliers, and on the customer side. Perfect machine quality can only be ensured through optimal production conditions. This ideology is also reflected in our systems.

Our production





Together, We Are MAPLAN

The extra mile – Individualised customer service adds value

An individual customer experience is the key to success. In an era of ever-growing digitalization, we prioritize personal relationships and empathy.

What do you really need? We put the benefits at the forefront. That's why we value long-term partnerships: familiarity breeds understanding, knowing where the shoe pinches, and what is needed.

A good relationship starts with a good conversation. Listening, asking the right questions - putting oneself in the other's shoes. That's how we build trust.

Together towards success

Diversity makes teams more successful. We are aware of this and promote mixed teams consisting of experienced, long-standing specialists and young talents. Optimal working conditions and an open approach to each other increase motivation and provide energy. We see the future as an opportunity and are open to the ideas and needs of our employees.

Trust forms the basis of our employee and business relationships.



Environmentally conscious into the future

MAPLAN pursues a holistic approach to sustainability. Therefore, we consider economic, ecological, and social aspects, creating an effective interplay. An efficient and sustainable use of resources is part of our corporate culture. This is not just lip service for us, but lived entrepreneurial responsibility for the benefit of all.

Sustainable Energy

We pursue a comprehensive approach, leveraging innovations such as air-to-water heat pumps. Currently, we operate two pumps on the roof with a total capacity of 120 kW. By harnessing ambient air as a heat source, they contribute to environmentally friendly heating of our buildings. MAPLAN also consistently advances renewable energy through photovoltaic systems. To better meet our demand of 500 MWh, we doubled our existing setup, now covering 90% of our energy needs.

Efficiency for Our Customers

For our customers, MAPLAN's initiatives primarily mean that our deeply held conviction permeates into machine manufacturing and extends all the way to the finished production process. Thanks to numerous technologies, our customers also achieve the highest efficiency in production:

- ⓪ Energy-efficient drive: Save up to 50% energy with MAP.cooldrive
- ⓪ Intelligent heating/cooling system: Up to 80% less energy consumption with MAP.dci units
- ⓪ Energy monitoring: Keep consumption in check with MAP.energywatcher
- ⓪ Minimal material loss during compound changes with the original MAP.fifo injection unit

MAPLAN from above



INGENIOUS CONTROL UNIT - WYSIWYG | **OPTIMAL
PROCESS TECHNOLOGY** | HIGHEST ENERGY EFFICIENCY
ATTRACTIVE DESIGN | **FAST & FLEXIBLE** | DURABLE

System Solutions with the **PLUS+**

MAPLAN - more than ever

What If Elastomer Injection Moulding Machines Could Operate as They Do Today, but with Less Power and Resource Consumption? No longer a theory, but a reality: MAPLAN machines boost productivity while reducing energy consumption with proven success. Our technology helps your employees work more smoothly, effectively, and thus more motivated to produce the best products for your company. To enhance the efficiency of your production, we offer a range of **MAPLAN+** benefits compared to conventional injection moulding technology.

More Productive with efficient processes

MAPLAN's cutting-edge technology is utilized where it can support production processes in a sensible and cost-effective manner. With MAPLAN technology, we create diverse opportunities to optimize the production process to meet the individual needs of our customers:

- ① Minimal pressure losses through the MAPfiffo injection unit
- ① Flexible and productive with MAPLAN automation solutions
- ① Process-optimized with the MAPcommander C6 control system

Economical with innovative solutions

- ① Increased process speed and enhanced movement speed
- ① Flexibility: Numerous individual process parameter settings
- ① Modular design creates solutions for all requirements and budgets
- ① Long lifespan through the use of robust technologies and high-quality components
- ① Most compact footprint on the market: up to 50 percent less space required in the production hall
- ① Attractive price-performance ratio

Advancement through simplification

- ① Maintenance-friendly design: Thoughtfully designed door systems allow easy access.
- ① Many models – one control unit: The MAPcommander C6 controls and documents all MAPLAN machines with extensive standard functions.

On-time with full productivity

- ① Produce on-time with full process accuracy:
 - High-quality parts, produced quickly with minimal scrap and waste
- ① Utilize user-friendly technologies for experts:
 - MAPfiffo injection unit for a broad processing window, excellent repeatability, optimal shear heating, and maximum curing speed
- ① Minimize process variations: The MAPcommander C6 visualizes processes and simplifies monitoring

Sustainability means energy-efficient production

- ① MAPcooldrive servo drive: Up to 50% less power consumption and no oil cooling required
- ① MAPfiffo Injection Unit: Up to 30% less material waste during cleaning and material change
- ① The Quietest Machine on the Market: Low-noise operation with MAPcooldrive
- ① MAPdci: Intelligent, consumption-based control of temperature units

Clever solutions for smart manufacturers

- ① Higher productivity with Industry 4.0 interface and digitalization
- ① Central control of robotics, automation solutions, and external peripherals with the MAPcommander C6
- ① Export data for MES and BDE systems using the Euromap77 interface and OPC-UA protocol

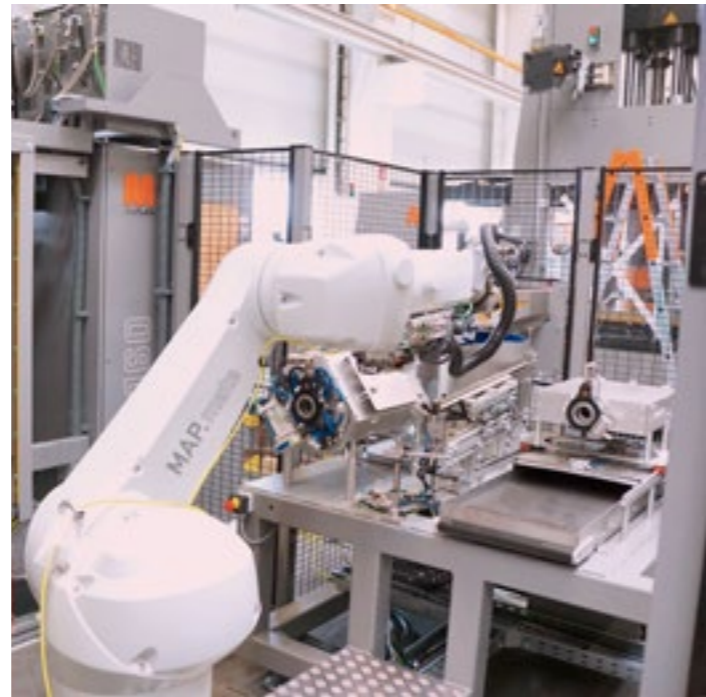

System Intelligence

360° Turnkey solutions tailor-made in house

At MAPLAN, we create customized solutions for our customers with a team of experienced experts. The result is a perfect synergy between injection moulding machines, options, and automation components. MAPLAN's automation portfolio ranges from simple shifting systems to complex implementations of linear or multi-axis robots. High-quality system components are combined by our specialists into an effective production cell. Specifically, the MAP.autocell manages the entire production process for your products, starting with pre-moulding operations up to post-moulding tasks. All components are centrally controlled via the MAP.commander C6 machine control system.

Your satisfaction is ensured by a single point of contact, providing a competent and reliable source of support. Behind this contact stands a team that smoothly handles complex requirements with ease. High-tech processes demand straightforward communication and solutions from a single source.



Tools



Robotic solutions



Cold runner

High Quality Production

MAPLAN injection moulding machines are used across the world in the following industries:

- ① Automotive
- ① Aerospace
- ① Railway technology
- ① Sanitary equipment
- ① Medical technology
- ① Water technology
- ① Construction, garden & electric
- ① Furniture & office supplies
- ① Household & white goods
- ① Oil production
- ① Alternative energy
- ① Security technology

These process technologies are standard:

- IM Injection Moulding
- ITM Injection Transfer Moulding
- 2K-IM Two compound Injection Moulding
- IC / OMI Injection Compression Moulding
- CM / TM Compression Moulding / Transfer Pressing



Horizontal, vertical, or C-frame?

In any case, a MAPLAN.

Different designs support specific applications and processing methods. MAPLAN offers a wide portfolio of over 40 models in all variants to meet any requirement. With various clamping systems and equipment options, we can guarantee you an optimal production system that perfectly suits your applications.

Horizontal

Efficient: Thanks to various demoulding devices and brushing systems

Flexible: Large daylight opening and long stroke for various mould concepts

Powerful: Especially for the production of precise small parts in large quantities

Specialized: For large series in fully automated production with minimal personnel effort

Vertical

Modular: Wide range with various clamping and injection units available

Productive: Fully automatable through advanced robotics, automation solutions, and peripherals

Versatile: Injection from above, below, or 2K

Specialized: Optimal for products with inserts and products with manual operation

C-frame

Ergonomic: Ideal working height and access from three sides

Versatile: Injection from top or bottom possible

Specialized: Optimal for the production of corner joints and small series

Presses

Simple: No injection unit required

Specialized: Ideal for manufacturing products that cannot be produced by injection moulding, as well as for small series of large-volume or large-area products



Horizontal

Efficient for new standards of economy

The horizontal **RAPID+** silicone and rubber injection moulding machines from MAPLAN are powerful and fast. These machines are designed specifically for high speeds and automated processes, supporting all common demoulding and automation concepts for fully automatic production. Thanks to full automation, personnel requirements are kept to a minimum. **RAPID+** is a true all-rounder with a proven track record!

Highlights

- ① Generously sized clamping unit with extremely high rigidity and parallelism
- ① Large daylight openings and extended clamping stroke for various mould concepts
- ① Optimized for processing challenging elastomers
- ① Various demoulding devices and brushing systems available
- ① Nearly flash free production of sealing elements or moulded articles possible
- ① Cold runner-ready
- ① Includes all **MAPLAN+** benefits

Models:

TYPES	CLAMPING FORCE [kN]	INJECTION VOLUME [cm ³]	HEATING PLATE DIMENSIONS	
			[Standard mm]	[Enlarged mm]
RAPID+ 200	2000	200 – 1000	510 x 510	570 x 570
RAPID+ 300	3000	200 – 2600	595 x 630	670 x 670
RAPID+ 400 / 460	4000 / 4600	200 – 4000	875 x 875	740 x 1000
RAPID+ 570 / 630	5700 / 6300	200 – 8500	810 x 980	810 x 1100
RAPID+ 800	8000	3500 – 8500	1000 x 1100	1000 x 1200

MAP.motion: Self-optimised movement of the clamping unit - for faster set-up of the optimum process sequence

Optimum temperature distribution due to edge strip insulation and isobars

Intuitive operation with the MAP.commander C6 controller

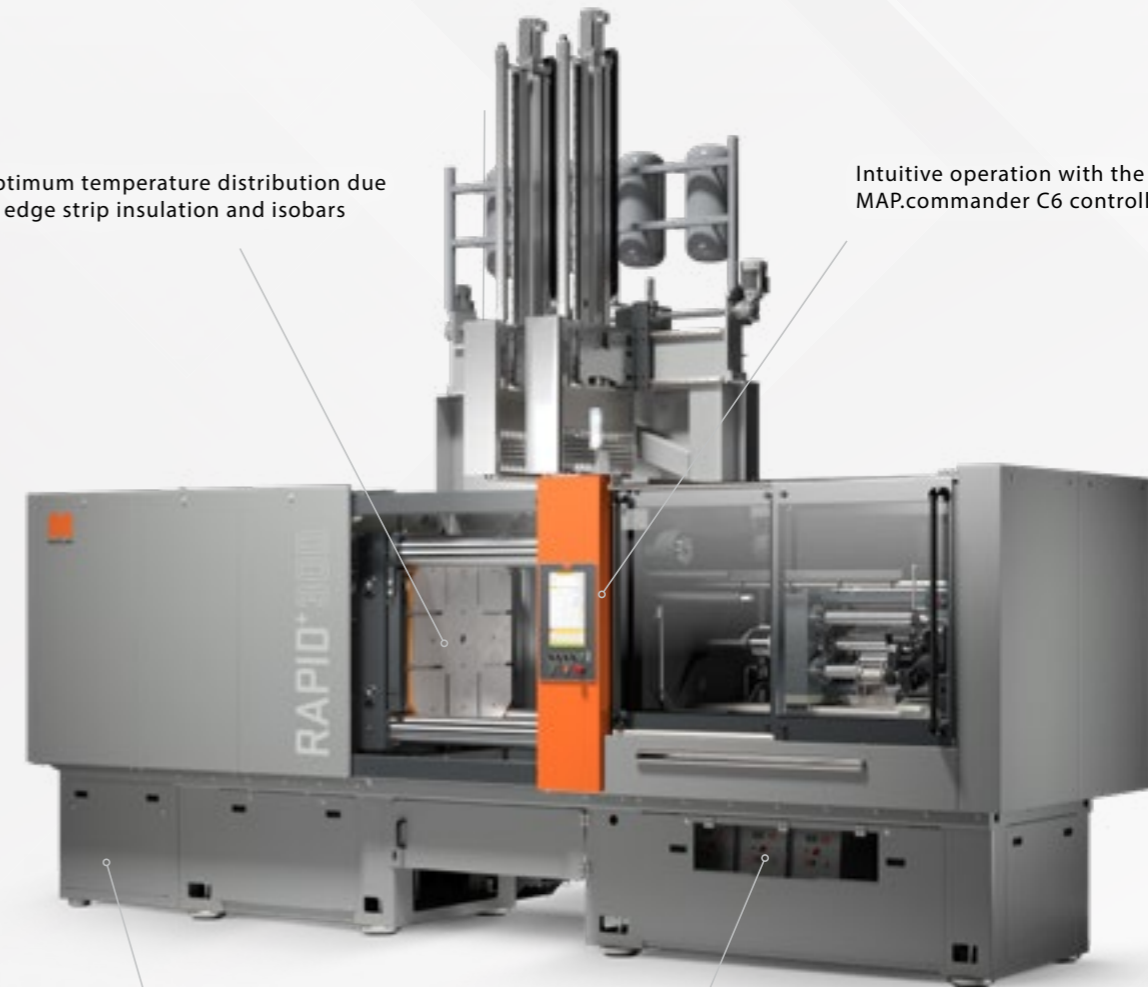

Faster cycle times thanks to highly dynamic MAP.cooldrive unit

Ideal use of space - possible to integrate up to 6 heating/cooling units



Vertical

Ergonomics across the board

Precise & versatile - the vertical MAPLAN **ERGO⁺** injection moulding machines are designed to suit a variety of requirements and impress with their high quality and optimised repeatability. The entire **ERGO⁺** series comes equipped with the energy-saving servo-hydraulic MAP.cooldrive and the high-precision MAP.fifo injection unit.

Highlights

- ⊖ Ergonomic operating height
- ⊖ Compact machine design cast in one pour
- ⊖ High flexibility for efficient automation and tailor-made customer solutions
- ⊖ Cold runner ready
- ⊖ Comes with all MAPLAN⁺ benefits
- ⊖ Maintenance-free platen parallelism for a life time

Models:

TYPES	CLAMPING FORCE [kN]	INJECTION VOLUME [cm ³]	HEATING PLATE DIMENSIONS	
			[Standard mm]	[Enlarged mm]
ERGO ⁺ 90	900	200 – 1000	300 x 400	390 x 500
ERGO ⁺ 160 / 180	1600 / 1800	200 – 2600	450 x 510	535 x 550
ERGO ⁺ 250 / 280	2500 / 2800	200 – 4000	560 x 650	670 x 700
ERGO ⁺ 250XL / 280XL	2500 / 2800	200 – 4000	560 x 780	670 x 800
ERGO ⁺ 320	3200	200 – 4000	670 x 780	760 x 850
ERGO ⁺ 400 / 460	4000 / 4600	2000 – 8500	710 x 800	820 x 900

Automatic strip tear control and optimised strip feed for a hassle-free production process

Exceptionally short cycle times with the help of the MAP.cooldrive unit

MAP.logicmoves: freely programmable additional movements, which can be electric, hydraulic or pneumatic



MAP.smartlight for visualising the state of the machine - ideal for multi-machine operation

Optimal accessibility due to additional space below the machine



Vertical

The new size

We are pushing boundaries when it comes to size, precision and processing quality with the help of our new vertical **ERGOMAX⁺** series, whether in the fully or semi-automatic production of elastomer articles. The entire **ERGOMAX⁺** series comes equipped with our energy-saving servo-hydraulic MAP.cooldrive as well as our high-precision MAP.fifo injection unit.

Highlights

- ⊖ Ergonomic operating height despite larger machine
- ⊖ Flexible adjustment for different tool heights
- ⊖ Optimally adaptable to customer specifications
- ⊖ Can be enhanced with MAPLAN automation and robotics concepts
- ⊖ Cold runner ready
- ⊖ Comes with all MAPLAN⁺ benefits
- ⊖ Maintenance-free platen parallelism for a life time

Models:

TYPES	CLAMPING FORCE [kN]	INJECTION VOLUME [cm ³]	HEATING PLATE DIMENSIONS	
			[Standard mm]	[Enlarged mm]
ERGOMAX ⁺ 460 / 500	4600 / 5000	700 – 8500	710 x 800	820 x 1000
ERGOMAX ⁺ 570 / 600	5700 / 6000	700 – 22500	810 x 1000	950 x 1100
ERGOMAX ⁺ 720 / 780	7200 / 7800	700 – 22500	900 x 1000	1040 x 1250
ERGOMAX ⁺ 900	9000	6000 – 22500	1100 x 1350	1230 x 1400

MAP.fifo ergo injection unit with all FIFO-advantages and ergonomic intake height

High platen-parallelism for optimum tool support

Functional diversity with the MAP.commander C6 controller



Multiple synchronised ejectors

Low operating height with increased clamping force



Vertical

Tried and tested at the **highest level**

Come prepared for a variety of applications with the help of the vertical **CLEVER+** injection moulding machine in the basic model from 160 to 400 tons. You can also take advantage of numerous MAPLAN+ benefits with the **CLEVER+** series.

Highlights

- ⊖ Most compact footprint in its category on the market
- ⊖ Particularly cost-effective
- ⊖ MAP.commander C600 for optimum user-friendliness
- ⊖ With reliable axial piston pump drive
- ⊖ Combines functionality with attractive design

Models:

TYPES	CLAMPING FORCE [kN]	INJECTION VOLUME [cm ³]	HEATING PLATE DIMENSIONS	
			[Standard mm]	[Enlarged mm]
CLEVER+ 160 / 180	1600 / 1800	200 – 1000	450 x 510	535 x 550
CLEVER+ 250 / 280	2500 / 2800	200 – 2600	560 x 650	670 x 700
CLEVER+ 400 / 460	4000 / 4600	200 – 4000	710 x 800	820 x 900

High process accuracy and less material waste with the MAP.fifo injection unit

Proven APP hydraulic unit

MAP.commander C600 for optimum user-friendliness

Compact footprint for optimum use of space

Optimum accessibility to all machine components



C- Frame

Providing **maximum accessibility** to the working area

The MAPLAN C-frame design has proven to be excellent for the production of specific rubber and TPE articles in the clamping force range of 20 to 250 tons. It offers a highly compact solution with open access to the work area.

The **EASY+** series is perfect for the semi- or fully automatic production of moulded corners and technical moulded parts.

Highlights

- ⊖ Intelligent one-piece design with very small footprint
- ⊖ Ideal accessibility from 3 sides
- ⊖ Ergonomic working height
- ⊖ Many options available
- ⊖ Simple operation with the MAP.commander C600 control unit
- ⊖ Comes with many MAPLAN+ benefits

Models:

TYPES	CLAMPING FORCE [kN]	INJECTION VOLUME [cm³]	HEATING PLATE DIMENSIONS	
			[Standard mm]	[Enlarged mm]
EASY+ 20	200	50 – 250	300 x 300	auf Anfrage
EASY+ 30	300	50 – 250	300 x 300	auf Anfrage
EASY+ 50	500	50 – 300	600 x 500	auf Anfrage
EASY+ 100	1000	50 – 1000	700 x 500	auf Anfrage
EASY+ 160	1600	50 – 1000	1000 x 700	auf Anfrage
EASY+ 250	2500	50 – 1000	800 x 700	auf Anfrage

High-precision compact injection moulding machine with MAP.fifo injection unit

2-hand operation integrated in the control panel

Ideal 3-sided accessibility to the mould



Ergonomic operating height

Very small footprint



FORCE+

Presses

No injection unit needed

The MAPLAN **FORCE+** is the perfect companion for special press applications. Once again, you can benefit from a range of MAPLAN+ advantages with this series. All MAPLAN models are available in a press version.

- ⊖ Highest level of precision
- ⊖ Particularly cost-effective for a press of Austrian quality
- ⊖ MAPLAN automation solutions available
- ⊖ Retrofitting of a MAP.fifo injection unit possible

All accessories available from the injection moulding machine range

High platen-parallelism for optimum mould support



MAP.commander C600 control more than perfect for the pressing process

Optionally available with APP or MAP.cooldrive unit

Optimum accessibility to all machine components

BOTTOM+

Vertical

The unique **BOTTOM+** design is suitable for special mould designs that require injection into the mould from below. **BOTTOM+** models are available with various clamping forces and come with all customary MAPLAN+ benefits.

- ⊖ Alternative injection unit systems available depending on size
- ⊖ Well proven screwram injection unit available for larger volumes
- ⊖ Ergonomic accessibility to strip intake

MULTI+

Vertical

Two compounds - one solution

With MAPLAN's dual compound technology, two elastomer compounds can be injected sequentially, simultaneously or with a timed delay. This allows for new techniques in the production of high-tech articles with special geometry or special mechanical properties.

Top MAP.fifo injection unit

MAP.fifo injection unit

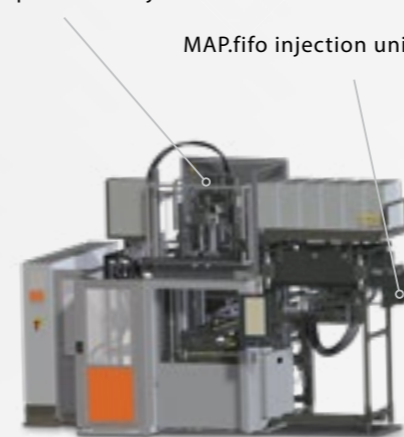

2K Splitline

- ⊖ One injection unit from the top, one injection unit horizontally from the side
- ⊖ Versatile, as it can also be used as a single compound machine
- ⊖ Different configurations of the second injection unit possible

2 Top MAP.fifo Injection units



2K Top

- ⊖ 2 injection units from the top
- ⊖ Same footprint as a single compound injection moulding machine
- ⊖ Available with up to three hydraulic drives for faster processes

Vertical

The Prerequisite for large-sized seals

The new large-scale machine series from MAPLAN with a vertical clamping unit - ideally suited for the production of large-dimension and high-performance seals, such as those for electric vehicle battery cases.

- ① **Gigantic plate sizes** realized by robust machine design **with 4 clamping cylinders, forms up to 2.500 x 2.000 mm are possible**
- ① **Versatile injection units:** Can range from very small (200ccm) to very large, including dual-compound (2K) combinations
- ① **Exceptional part quality precision:** Highly efficient machine concept combined with maximum injection accuracy
- ① **Comprehensive automation and options portfolio:** Shuttle devices, heated platen shifting, and more

The new MAPLAN large machine series with a vertical clamping unit is ideal for producing large and high-performance seals, such as those for electric vehicle battery cases.

Twin-Ram

Fast double-shuttle for very short cycle times



Quattro-Ram

Suitable for the production of rubber and silicone



MAPLAN Resource-Efficient Technology

MAP.cooldrive | Efficient and quiet

The intelligent servo-hydraulic **MAP.cooldrive drive system** automatically adjusts the motor speed to match the actual power demand during the production cycle.

- ① Up to 50% energy savings
- ① Noise emission reduced by more than 50%
- ① No consumption in standby mode
- ① No external oil cooling required
- ① Extremely dynamic movements
- ① Low maintenance
- ① Long lifespan



MAP.dci | Demand Control intelligence

MAP.dci provides demand-oriented flow control and intelligent regulation, resulting in significantly lower power consumption compared to conventional temperature control units.

Energy consumption



- ▶ MTG 189
- ▶ **MTG 189 DCI**

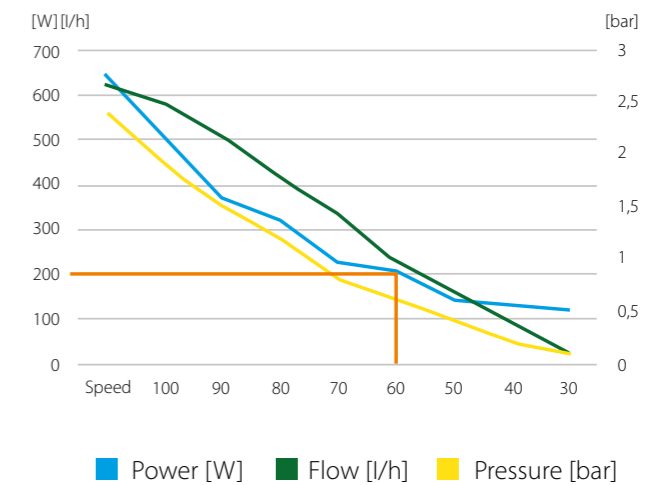

MAP.fifo | The Original

The key advantages of the **MAP.fifo** injection unit, invented by MAPLAN, lie in its unrivaled performance, system precision, and simplicity of design. The **MAP.fifo** is available in three versions: the classic **MAP.fifo** original, **MAP.fifo ergo** with an easily accessible strip feeding opening, or **MAP.fifo retract** with a retractable nozzle for varying immersion depths into the mould.

- ⊖ Very short nozzle: Minimal pressure loss
- ⊖ Minimal residual material: From shot to shot
- ⊖ High-precision repeatability
- ⊖ Wide processing window
- ⊖ Easy maintenance and cleaning
- ⊖ Simplified operations
- ⊖ Fast material change: Facilitates quick transitions between materials with less wastage



MAP.fifo **original**



MAP.fifo **ergo**



MAP.fifo **retract**

Product Carbon Footprint Digital Analysis

Our latest software extension for machine control leverages the energy monitoring function to digitally capture and calculate the CO2 footprint in production. This leads to more sustainable

production processes and their complete documentation. Customer-specific data on primary energy sources and used materials enable precise monitoring of energy consumption and CO2 emissions per product. This continuous analysis helps manufacturers reduce their production's ecological footprint and consistently improve energy efficiency.



All-in-one 360° Systems from MAPLAN

Everything from a Single Source

MAPLAN handles the entire implementation of MAPautocell projects from concept to final product for the client. Project planning, cell layout, robots, and all automation components, as well as the safety area, are perfectly coordinated. MAPLAN manages the project through to commissioning, acceptance, and the fine-tuning of all components. You benefit from a single point of contact for all matters and components. Projects with certified MAPLAN premium technology partners reduce engineering costs, shorten the implementation phase, and ensure smooth functionality.

MAP.autocell

MAPLAN 360° Turnkey solution
Injection Moulding Systems include upon request:

1. Injection moulding machine
2. Cold runner technology MAP.crb
3. Tools
4. MAP.mate robotic systems
5. Handling systems & conveyor belts
6. Brushing and demoulding systems
7. Testing equipment & quality control
8. Safety components
9. Individual automation components
10. Printers, lasers...



Everything from
a single source

The MAPLAN Toolshop

Due to our extensive in-house manufacturing, MAPLAN creates independence in production and thus control over all manufacturing processes. We guarantee our customers the highest quality, on-time delivery, and reliability.

MAPLAN as a global full-service provider

MAPLAN's global expansion enables comprehensive supply to our customers with cold runners and moulds from our production facilities and toolshop partners in the USA and India. By integrating machinery and mould making with automation technology, we respond flexibly to customer requirements worldwide, providing our customers in industries such as automotive, industrial, electrical, agriculture, and healthcare with significant competitive advantages.

Manufacturing locations with expertise

In our Slovakia plant in Malacky, a state-of-the-art production facility spans 3500 m², equipped with turning centers for complex parts, laser cutting machines, CNC milling machines, and a modern powder coating system. Our subsidiary rt-formtec specializes in the processing of large moulds up to 2.500 x 2.200 mm and has extensive machinery for tool and cold runner blocks manufacturing.

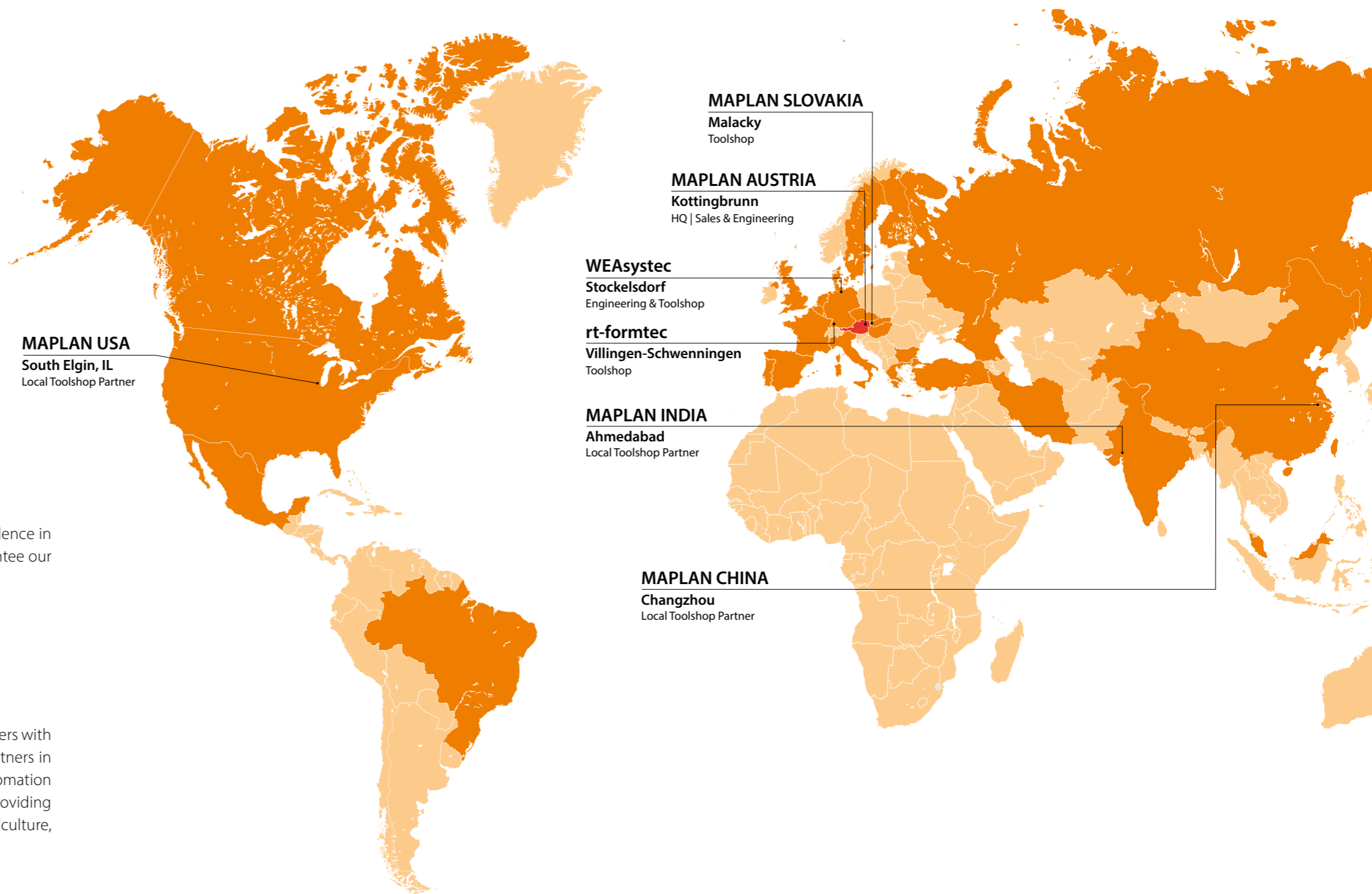

- HEADQUARTERS
AUSTRIA
- SUBSIDIARIES,
SALES & SERVICE
- SUPPORTED BY
HEADQUARTERS

Through collaboration with WEAsystec and rt-formtec, MAPLAN has been able to massively expand its expertise in mould making and automation technology. Additionally, manufacturing capacities have been significantly increased, at our the plant in Malacky, Slovakia. This integration over the past few years has positioned MAPLAN as an even stronger partner for complete solutions in machinery, moulds, cold runners, and automation technology.



Increase profitability with MAP.crb Cold Runner Systems

Produce efficiently with less compound:

MAPLAN ensures maximum performance, productivity, and profitability in elastomer processing with intelligent technologies. Rising raw material prices, high disposal costs, and constant cost pressure force companies to continuously improve their performance and produce in an environmentally friendly manner. Therefore, we offer various cold runner systems that guarantee our customers particularly high efficiency in the production of rubber and elastomer articles. When cold runner systems are used correctly, producers gain many advantages compared to hot runner distributors.



Product overview

A MAP.crb for all applications

MAPLAN offers various cold runner systems for a variety of applications. Each system features unique characteristics and is tailored specifically for your production processes. The MAPLAN project team is happy to advise you.

SLIM



- Slim design saves daylight distance
- Easy & quick installation
- Very few wearing parts
- No cold runner heating plate required

SOLID



- Optimal heating contact area with mould
- Suitable for high-pressure applications
- Low-maintenance, robust solution
- Optionally available as **solid+** with manual nozzle flow adjustment

SPLIT



- Good for multi-colored materials
- Easy compound change
- Access to rubber channels for quick cleaning
- Optimal heating performance
- Good for non-symmetrical nozzle layouts

PINPOINT



- Based on MAP.crb solid
- Hydraulic needle shut-off nozzles
- For the highest injection pressures
- Optionally available as **pinpoint+** with mechanical nozzle stroke adjustment

ITM



- High number of nozzles possible
- Flexible with nozzle positions
- Suitable for small & precise parts
- Material savings & waste reduction

**VALVE
GATE**



- External CRB needle valve control
- Flexible use on different machines
- Applicable on machines from other manufacturers
- Control via time, volume, or pressure sensors

The **intelligence** of the MAPLAN machine

MAP.commander C6 - Control intelligence

MAPLAN machines are known for their fundamental consistency, their user-friendly interface design and the versatility of their settings to configure and simplify the production process. The latest version of the intuitive touchscreen interface between user and machine boasts a 30 percent faster touch response time compared to its predecessor. With only one basic control and operation method, all MAPLAN models can be operated in the same way. The MAP.commander functions as the central unit: no matter the upgrade level - from the smallest and simplest machine to the high-end system with full automation.

Increased efficiency through individualisation

- ⊖ Drag & drop cycle configuration for up to five parallel sequences
- ⊖ MAP.logicmoves: Freely programmable control of external equipment
- ⊖ Valve gated cold runner: up to 32 valve gates individually controllable
- ⊖ MAP.motion: Self-optimising movements of the clamping unit / ejector

Secure access and data

- ⊖ User-specific rights system
- ⊖ Archiving of cycle configuration, process parameters and alarm protocol

Foresight instead of hindsight

- ⊖ Diagnostic display features traffic light system and targeted operator guidance in the event of an error
- ⊖ Alarm system with help function
- ⊖ Maintenance program recommends maintenance activities

MAP.advanced package

Do you always use your machines to their fullest potential? With the MAP.advanced package you can visualise your injection process in order to determine the best possible process and guarantee the highest part quality.

- ✓ Prozess graph / injection graph
- ✓ MAP.limit envelope curves
- ✓ Plasticising graphic
- ✓ Trend graphs

C6000
21" Touchscreen



MAP.commander C6 machine control

- Automation
- Real-Time data
- Control
- Monitoring
- Robotics solutions
- Customisation
- Remote maintainance

Process optimisation increase in efficiency



C600
15" Touchscreen

MAP.commander CC cell control: The control system for the complete production cell

- ⊖ Same look & feel
- ⊖ Same operating logic
- ⊖ Same hardware
- ⊖ All processes synchronised
- ⊖ Everything at a glance at all times
- ⊖ Simple operation
- ⊖ 2 operating units per cell possible

MAP.mate robotic solutions:

More **agility** and **flexibility** in the production

Sustainably economical automation with the highest precision

Robots manage to move from very small to large components with high speed and precision. In this way, more output is achieved with the same production time. Robots ensure high quality and optimise production costs at the same time.

MAP.mate 6-axis-robot

Model	Reach (mm)	Load capacity (kg)
Map.mate 40	515	2,3
MAP.mate 60	670 L 920	3,7 L 4,5
MAP.mate 90	1000 L 1200	14 L 12
MAP.mate 140	1450	40
MAP.mate 160	1710 L 2010	40 L 25
MAP.mate 200	2194 L 2594	130 L 80

MAP.mate 90 also available as XL: **1450 mm | 7 kg**

Typically used for:

Plate handling, machine tending, demoulding, mould cleaning, spray applications



- HIGH PRECISION
- LONG LIFETIME
- LOW MAINTENANCE
- COMPLETELY INTEGRATED INTO MAP.commander CC

- ENABLES 24/7 PRODUCTION
- INCREASED OUTPUT
- SAFE USE
- ELIMINATION OF STAFF-INTENSIVE TASKS

MAP.mate SCARA-robot

Modell	Reach	Load capacity
SCARA 40	460	8,4
SCARA 60	620	8,4
SCARA 80	800	8,4
SCARA 100	1000	8,4

Typically used for:
Preparation of inserts, sorting of finished parts, preparation for inspection applications



Be connected Every MAPLAN is network-ready

MAPLAN relies on the advantages of Industry 4.0 and has been investing in digital development for years to enable our customers to benefit in areas such as production, planning, control, and maintenance. The result is the ability to digitally network MAPLAN production cells or machines with our customers' server systems, to deliver production data to MES systems or BDE systems.

- ① Every MAPLAN machine with the new MAP.commander C6 control system is network-ready
- ① Authorized personnel can access the machine anytime and from anywhere
- ① Allows control of production progress in real-time or through log files and protocols
- ① MAP.mes: MAPLAN interface for MES systems based on OPC-uA
- ① MAP.mes advanced: the professional interface provides data for MES systems: Monitoring, statistics, support, remote maintenance, etc
- ① Integration into higher-level ERP systems
- ① Central documentation of processes and recipes
- ① Secured data in a private VPN network

Both the standard 15" touchscreen and the luxurious 21" touchscreen variant feature a simple operating concept that makes even complex processes understandable and transparent. Thanks to the web-based HTML5 technology, the MAP.commander software can also be accessed on any other device, such as a laptop or iPad, in the respective language. This allows you to have remote access to the machine's settings and data. With the appropriate configuration and access rights, you can even intervene in the process remotely. Conflicts between the machine operator and external access are excluded due to separate user interfaces (sessions).



Higher productivity through automation

Turn your horizontal RAPID+ into a **fully automatic** production cell

Our robust brush systems for automatic demoulding and cleaning are among the most effective automation options for horizontal injection moulding machines. They enable the fully automatic production of all free-falling articles such as O-rings, sealing elements and moulded articles.

- ① Cost-effective automation solution
- ① Single or double brush design
- ① Up to three vertical units possible
- ① Precise demoulding processes due to rigid design
- ① Individual cycle configuration of movements
- ① Full integration in the MAPcommander C6 including diagnostics
- ① Fast, precise movements through servo-drives
- ① Many possible configurations: Spraying and blowing devices, ejector plates or gripper systems



Optimise your processes

MAPLAN offers a wide range of multifunctional automation modules for process optimisation and shortened cycle times.

- ① Modular automation kit
- ① Increase the productivity and energy efficiency of your facility
- ① Fast and precise movements thanks to efficient servo-drives
- ① MAPautocell: Individual solutions for fully or semi-automatic production
- ① Centralised control system of all components with MAPcommander C6
- ① Additional components can be easily integrated into the cycle configuration
- ① Integration into the visualisation, diagnostic and alarm system

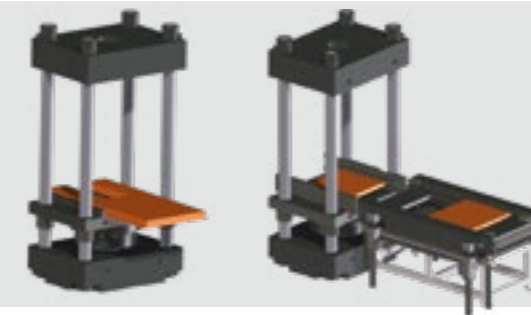

Heating plate shifting / changing

- ① Heating plate shifting enables improved ergonomics
- ① Increased output through exchanging the heating plates (two lower mould halves)



Frame shifting / changing

- ① Cost-effective solution for centre plate exchange or shifting (One or two plates)
- ① Manual or hydraulic

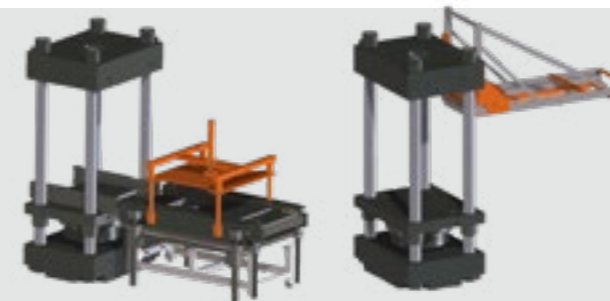

Middle plate change

- ① Increased output using two centre plates
- ① Increased productivity through synchronised change of centre plates

External ejector (left) Sprue removal device (right)

Partnership right down the line

Service with intellect and insight

We at MAPLAN are known for our remarkable customer service. What sets us apart in this regard? A high level of technical know-how, years of experience, short response times and effective communication. We are there for our customers, we understand their problems and we find solutions! We see our customer-supplier relationships as partnerships.

The worldwide MAPLAN service branches across numerous European countries, the US, Mexico and China all guarantee our level of customer service through trained technicians and engineers.

- 🕒 Hotline for immediate troubleshooting
- 🕒 Commissioning & machine relocations
- 🕒 Repairs & Refurbishing
- 🕒 Maintenance and service contracts

Original MAPLAN spare parts

We keep over 90 percent of all MAPLAN original spare parts available in stock. As soon as the order is received, it is dispatched immediately, and with express delivery if requested. With high quality MAPLAN original spare parts you can trust in the availability of your machines.

MAP.easyparts: Individual 3D spare parts catalogue for every machine

- 🕒 Quicker to the part: Simply visually search for spare parts on the computer
- 🕒 No incorrect orders due to MAPLAN order number being visible on the selected part
- 🕒 Simple forwarding of the order information

Preventive packages

MAPLAN recommends the following three preventive packages to ensure a high availability of your machinery:

1. MAP.firstaid

Comes with the most important small parts that ensure smooth production and avoid unnecessary machine downtimes.

2. MAP.care

All the parts your service team needs to carry out regular maintenance.

3. MAP.care+

MAP.care package including sensors, thermocouples, insulation boards, heating elements, etc.

MAPLAN Maintenance contracts

Do you monitor your machines regularly? Inspections enable the early detection of potential production breakdowns and their causes. In this way, machine failure and consequential damage can be avoided. Maintenance contracts also enable better planning of service intervals, increase the availability of the machines and reduce the risk of delivery delays.

A MAPLAN maintenance contract includes the examination of the following aspects and areas:

- 🕒 Functional check
- 🕒 Safety devices
- 🕒 Electric & hydraulics
- 🕒 Plasticising and injection unit
- 🕒 Clamping unit and ejector systems
- 🕒 Lubrication
- 🕒 Options, if available on the machine

Training: In-house experts

Deepen the technical knowledge of your employees to make sure you are getting the best out of your MAPLAN machines. The combination of know-how and optimisation offers real added value for practical implementation. We offer a wide range of training courses from straight forward seminars for operators and engineers to individual coaching sessions.

- 🕒 User training – BASIC
- 🕒 User training – ADVANCED
- 🕒 Service & maintenance
- 🕒 Rubber technology for injection moulders
- 🕒 Set-up & sampling of moulds
- 🕒 Process optimisation - Basics
- 🕒 Individual coaching for optimisation



Immediate help from the expert

MAP.remote maintenance

The remote diagnosis package MAP.remote offers the benefit of immediate assistance without needed on-site service engineers. This is not only practical, but also saves costs and emissions!

TELELOOK® & MAP.eye webcam

With TELELOOK® or the MAP.eye webcam, the process or service engineer is fully aware of the current state of the machine and can access all machine parameters and provide the necessary instructions for solving the issue over the phone.

Make it easy

- ⓪ Access is independent of time and location
- ⓪ Direct video transmission for error analysis
- ⓪ Remote configuration possible
- ⓪ Always up to date: Updates can be installed remotely

Inexpensive and fast

- ⓪ Immediate assistance from the service or process engineer
- ⓪ Increase machine availability
- ⓪ No onsite engineer needed, therefore no travelling costs involved

Secure

- ⓪ Two-factor authentication
- ⓪ Powerful VPN network
- ⓪ Professional data centre for fast data transfer
- ⓪ IPsec protocols & AES 256 bit encryption



Service Hotline:

+43 225 2790 9091 56 | helpdesk@maplan.at

MAP.refit From old to new

An outdated machine does not have to be replaced but can often be updated with low financial investments, making it more economical and more productive. Our team will work with you to develop the ideal package for you. You choose the scope: From the uncomplicated replacement of worn out components, new heating plate systems all the way to the entirely new construction of the machine - everything is possible.

- ⓪ Extension of machine service life
- ⓪ No risk: Improved machine availability
- ⓪ Increased productivity or larger processing scope
- ⓪ Smaller financial investment versus a new acquisition

X6 controller upgrade

Would you like to integrate new processes and optimise existing ones? Upgrade now and benefit from all MAP.commander C6 functions. The X6 package boasts the full range of functions, just like the new MAPLAN models:

- ⓪ Connectivity features & interface to Industry 4.0
- ⓪ Real-time production data & statistics with helpful visualisations
- ⓪ Fast cycle configuration and self-optimising motion sequences
- ⓪ Consumption optimisation
- ⓪ Improved diagnostics & security features



MAPLAN Worldwide

MAPLAN USA
South Elgin, IL
Sales office | After sales



Stockelsdorf / Germany

In Stockelsdorf, MAPLAN combines its expertise with WEAsystec at one location, thereby deepening the collaboration for complete solutions in machinery and automation technology.



South Elgin / USA

Since 2018, South Elgin has been the new MAPLAN hub in North America. At this location, all machine modifications for all MAPLAN machine types are carried out to competently and quickly handle refurbishments.



Malacky / Slovakia

Since 2018, MAPLAN has had its own plant in Slovakia. At the Malacky location, control cabinets are manufactured. The production of metal and sheet metal parts has been expanded in Slovakia, and the assembly of components has begun.



Changzhou / China

In 2017, our production for the Chinese market was opened in the High-Tech and industrial park of Wujin. The plant, with a size of 4,000 m², has a capacity of over 200 machines annually. The location in the greater Shanghai area offers perfect infrastructure, with numerous customers and suppliers based here.



Chambéry / France

For more than 30 years, our team has been serving the French market in sales and service. An in-house spare parts warehouse and 24-hour response times complete the service.

- HEADQUARTERS
- SUBSIDIARIES, SALES & SERVICE
- SUPPORTED BY HEADQUARTERS



Ahmedabad / India

In 2024, MAPLAN founded and opened a location in Ahmedabad, India, one of the fastest-growing economies worldwide, with a new competence center that integrates production, service, and development.

- MAPLAN SLOVAKIA**
Malacky
Production plant
- MAPLAN AUSTRIA**
Kottingbrunn
HQ | Sales office | After sales
Production plant
- MAPLAN GERMANY**
Stockelsdorf
Sales office | After sales
- WEAsystec**
Stockelsdorf
Engineering & Toolshop
- rt-formtec**
Villingen-Schwenningen
Toolshop
- MAPLAN IBERICA**
Porto
Sales office | After sales
- MAPLAN FRANCE**
Chambéry
Sales office | After sales
- MAPLAN ITALY**
Calvenzano (BG)
Sales office
- MAPLAN INDIA**
Ahmedabad
Sales office | After sales
Production plant
- MAPLAN CHINA**
Changzhou
Sales office | After sales
Production plant

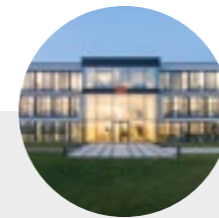

Headquarters / Austria

In 2016, MAPLAN invested twelve million euros in a new production plant with office building in the Eco-Plus industrial park in Kottingbrunn. The production was reorganized and switched from fixed-position manufacturing to flow production.

For nearly 50 years, MAPLAN has been a leading manufacturer of elastomer injection moulding machines and an expert in 360-degree system solutions for semi- and fully-automatic production of rubber and silicone products. We offer our customers expertise and reliability.

Due to our extensive in-house manufacturing, MAPLAN also creates independence in production and thus control over all manufacturing processes. We guarantee our customers the highest quality, on-time delivery, and reliability.



Villingen-Schwenningen / Germany

With rt-formtec in southern Germany, we have an experienced mould maker that produces high-quality moulds and cold runners.



Calvenzano / Italy

MAPLAN has been known in the Italian market as a reliable sales and service partner thanks to many years of experience and collaboration with ST.A.TE Technologies S.r.l since 2007.



Iberica / Spain

After years of collaboration, Spain and Portugal became a MAPLAN location in 2020, based in Porto, and increasingly serve industries such as automotive, electricity, medical, and others.

We are there for **you**

You are in good hands with our friendly and competent team. Our main concern is to give you the best guidance and consulting. Customers come first, as we focus on your needs:

- ① We evaluate your requirements and clarify the next steps in collaboration with you
- ① We demonstrate competence and reliability that guarantees a stress-free implementation
- ① We think innovatively and update you on the latest technical trends
- ① We co-operate with you in a respectful, friendly and precise style

We have established and **excellent co-operation** with MAPLAN. The basis is close coordination as well as flexibility and will to implement special adjustments.

Dipl.-Ing. Erwin Rudolf Mach,
Managing Director, Erwin Mach Gummitechnik, Austria

We are very satisfied. To date, we have managed to reduce the material waste by approximately 30 percent.

Antonio Da Costa, Technical &
Technical & Industrialisation Manager at SIMP, France

The production was automated in a **cost-saving and employee-friendly** way. At the same time, the output was increased by 30 % and the quality noticeably improved.

Robert Kusch, Director Operations
Production Manager for elastomer articles, WESTLAND, Germany



International Expert-Network

HEADQUARTERS

AUSTRIA

MAPLAN GmbH
Maplan-Straße 1
2542 Kottlingbrunn
AUSTRIA
+43 2252 790 909
office@maplan.at
www.maplan.at

SUBSIDIARIES

GERMANY

MAPLAN Deutschland GmbH
Albert-Einstein-Str. 46
23617 Stockelsdorf
GERMANY
+49 451 58345880
office@MAPLAN-germany.de

WEAsystec GmbH
Albert-Einstein-Str. 46
23617 Stockelsdorf
GERMANY

+49 (0) 451 / 87 206 - 0
info@weasystec.de

FRANCE

MAPLAN
2574, avenue des Landiers
73000 Chambéry
FRANCE
+33 4 79 96 31 02
office@maplan.fr

CHINA

MAPLAN (changzhou) Rubber
Machinery Co; Ltd
Building 1. No.377
Wuyi Rd,Wujin Hi-Tech Zone
Jiangsu Province
CHINA
+86 158 52 55 55 67
steve.hu@maplan.at

PORTUGAL/SPAIN

+351 939 015 390
vasco.ramos@maplan.at

USA / CANADA / MEXICO

MAchinery + PLANning Inc.
1655 North Lancaster Road
South Elgin, IL 60177
USA
+1 630 924 0100
office@MAPLAN-usa.com

ITALY

ST.A.TE Technologies srl
1655 North Lancaster Road
Via Vailate 15/a
24040 Calvenzano (BG)
ITALY
+39 0363 853209
sales2@state-art.it

INDIA

Maplan India Private Limited
Plot No 2102/1 Vatva GIDC Phase 4
Ahmedabad Gujarat 382 445
INDIA
+91 88667 07047
sales.in@maplan.at

AGENTS

BENELUX

+31 30 656 04 12
info@maplan.nl

BRASIL

+55 11 5522 9022
comercial@geromaq.com.br

BULGARIA

+359 32 96 93 95
info@diltech.bg

FINLAND

+358 40 776 2149
pasi.kontto@wiba.fi

GREAT BRITAIN

+44 1452 722733
sales@maplan.co.uk

GREECE & ZYPRUS

+30 2104833250
anbri11@yahoo.com

HUNGARY

+36 1 4369095
mate@thege-plastic.hu

IRAN

+98 21 444 55 123
+98 912 288 0 745
tecsystempars@yahoo.de

MALAYSIA

+603 3291 0388
khim@rics.com.my

SWEDEN

+46 35 155955
christian.hiljemark@battenfeld.se

CZECH REPUBLIC

+420 607 214 112
robert.smid@smid-a-spol.cz

TURKEY

+90 (312) 473 50 28
info@ergu.com.tr

RUSSIA

OOO „Kneader“
+7 (495) - 640-83-88
philippk@list.ru

MEMBER OF SOULIER GROUP

The SOULIER Group is divers and a reliable partner: from the planning, implementation, and management of large real estate projects to the worldwide production of rubber injection moulding machines and modern, sustainable modular construction buildings.

www.soulier-group.at



MAPLAN GmbH
Maplan-Straße 1 | A-2542 Kottlingbrunn | Austria
+ 43 2252 790 909 | office@maplan.at
www.maplan.eu

MEMBER OF SOULIER GROUP